

Fluid Power Designers'

LIGHTNING® REFERENCE HANDBOOK

Eighth Edition

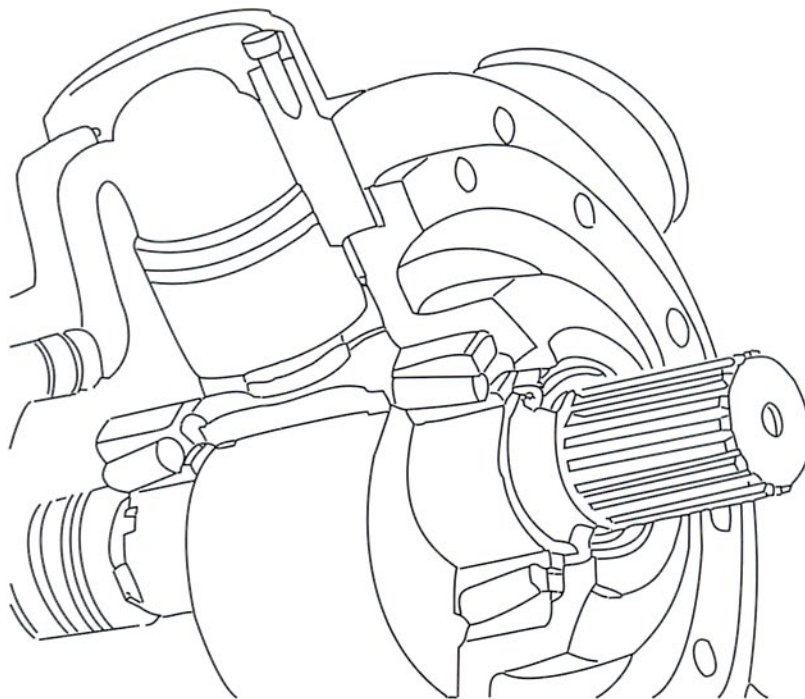

STANDARD ENGINEERING DATA
ANSI . API . ASTM . ISO . JIC . NEMA . NFPA . SAE . SI

Lightning Reference Handbook Table of Contents

	Page
Standards and Practices	
ANSI Standards for Stationary Industrial Machinery	4-37
ISO Fluid Power Graphic Symbols and Circuits	38-70
ANSI Subplate Standards	88-98
Fluid Power Data	
Abbreviations	189
Conversion Factors	71-75
Metric Units	76
Fluid Power Formulae	100-101
CV and Orifice Calculations	102-103
Prime Movers	
Selection of Induction Motors	77-80
NEMA Electric Motor Standards/Dimensions	81-83
Motor Starter/Fuse/Breaker Selections	84
Motor Amperage, Wire Ampere Capacity	85
Mounting Dimensions/Flanges/Shafts for Pumps/Motors	86-87
Electric Motor Horsepower to Drive Hydraulic Pumps	99
Transmission Lines, Connectors and Seals	
Pipe Specifications	104-106
Pipe Threads	108
Pipe Characteristics, Size, Schedule, Flow Rate	109
Pressure Drop vs. Fluid Flow	110-117
SAE Hose Specifications	126-129
SAE Tube Specifications	122-125
SAE O-Ring Ports	132
SAE Flange Ports	134-135
Water Hammer	107
Seals Compatibility	130-131
Dash Number/Thread Size Comparison	133
Tube-Hose-Pipe Equivalents	133
Fluids	
Hydraulic Fluids	141-147
Hydraulic Fluids Data	148-163
Fluid Conditioning	164-171
Viscosity Charts	146-147
Actuators	
Ram Capacities	140
Cylinder Push/Pull Forces	136
Cylinder Speeds	137
Fluid Motor Torque	138-139
Column Loading	174
Additional Information	
Reservoir Design	118
Heat Transfer	119
Pump Inlet Conditions	120
Pipe Bending	121
Accumulators	172-173
Noise Abatement	175-177
Glossary	
Standard Terms and Words	178-188
Index	
Index	190-193
List of Tables, Charts, Graphs	193

PIPE THREADS – AMERICAN STANDARDS

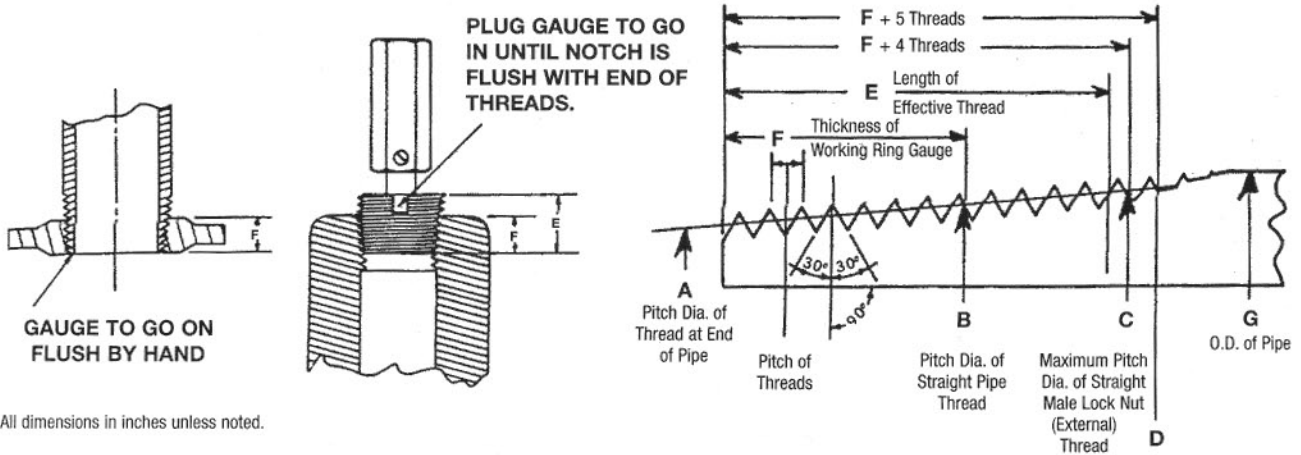

All dimensions in inches unless noted.

- A** equals $G - (0.05G + 1.1)P$
- B** equals $A + 0.0625F$
- C** equals $B + (4P \times 0.0625)$
- D** equals $B + (5P \times 0.0625)$
- E** equals $(0.8G + 6.8)P$
- F** equals thickness of Working Ring Gauge
- P** equals Pitch
- Total Taper 3/4 in/ft.
- Depth of Thread 0.8P

TOLERANCE FOR MALE THREADS:

One Turn Large (max. size), One Turn Small (min. size), from Face of Ring Gauge.

TOLERANCE FOR FEMALE THREADS:

One Turn Large (max. size), One Turn Small (min. size), from Gauging Notch.

THREAD DIMENSIONS IN INCHES

SIZE	A	B ^①	C	E ^②	F ^③	G	Pitch of Thread	Threads per Inch	Tap Drill Size
1/8	0.2834	0.2834	0.2907	0.2611	0.160	0.3125	0.02963	27	1/4
1/4	0.3750	0.3750	0.3844	0.2639	0.180	0.405	0.02963	27	11/32
3/8	0.47739	0.47739	0.4909	0.5073	0.200	0.540	0.04444	18	7/16
1/2	0.61201	0.62701	0.6409	0.6444	0.240	0.675	0.04444	18	37/64
5/8	0.7784	0.7963	0.808	0.5337	0.320	0.840	0.05714	14	23/32
3/4	0.90766	0.9388	0.955	0.6112	0.5457	1.050	0.05714	14	59/64
1	1.21363	1.2363	1.2658	0.6828	0.400	1.315	0.06957	11 1/2	1 1/2
1 1/4	1.55713	1.5838	1.6051	0.7068	0.420	1.660	0.06957	11 1/2	1 1/2
1 1/2	1.799	1.82234	1.8441	0.7235	0.420	1.900	0.06957	11 1/2	1 1/2
2	2.29627	2.3180	2.3234	0.7565	0.436	2.375	0.06957	11 1/2	2 3/16
2 1/2	2.71953	2.76216	2.7934	1.1375	0.682	2.875	0.100	8	2 9/16
3	3.34062	3.38850	3.4198	1.2000	0.766	3.500	0.100	8	3 3/16
3 1/2	3.83750	3.88881	3.9201	1.2500	0.821	4.000	0.100	8	3 11/16
4	4.33438	4.38712	4.4184	1.3000	0.844	4.500	0.100	8	4 9/16
5	5.39073	5.44929	5.4805	1.4063	0.937	5.563	0.100	8	5 5/16
6	6.44609	6.50597	6.5372	1.5125	0.958	6.625	0.100	8	6 5/16

① Also pitch diameter at gauging notch

② Also length of plug gauge

③ Also length of ring gauge

INFORMATION ABOVE TAKEN FROM AMERICAN STANDARD FOR PIPE THREADS, ANSI - B2.1

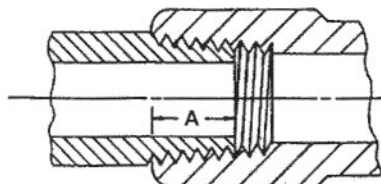

THREAD ENGAGEMENT

Size	1/16	1/8	1/4	3/8	1/2	3/4	1	1 1/4	1 1/2	2	2 1/2	3	3 1/2	4	5	6
A	3/16	1/4	3/8	3/8	7/16	9/16	9/16	5/8	5/8	3/4	7/8	15/16	1 1/16	1 1/8	1 1/4	1 5/16

NO ALLOWANCE FOR VARIATION IN TAPPING AND THREADING
FOR BEST RESULTS, TAP DRILL HOLES SHOULD BE REAMED TO THE DEPTH OF THREAD WITH A 3/4 IN/FT REAMER.